

This drawing is for reference only, not for manufacturing unless approved by client.

- 1 Design pressure 300PSI(2.1MPa)
- 2 Design temperature 150°F(66°C)
- 3 Min. allowable temperature 14°F(-10°C)
- 4 Working medium, water PH 3-11
- 5 Internal permeate pressure not to exceed 125PSI(0.88MPa)
- 6 Please operate according to directions
- 7 Subject to chance without notice, please sign in the website of the company to inquire.(www.ropv.com.cn)

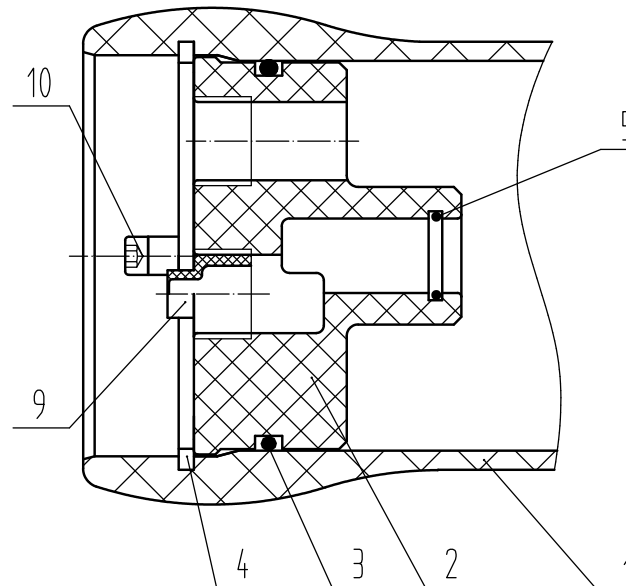

10	GB/T70.1 M6*20	Locking Crescent Screw	4	304SS	4012
9	4013	Plug	1	ABS	NPT 3/4" M
8	4010	Saddle	2-3	Rubber	
7	GB/T5782 M8*60	Strap Screw	4-6	304SS	4009
6	4008	Strap	2-3	304SS	
5	19x2.65G GB/T3452.1	O-Ring	2	EPDM	4007
4	4011	Locking Crescent	4	304SS	
3	90x5.3G GB/T3452.1	O-Ring	2	EPDM	4002
2	4099Z	End Plate	2	ABS	3/4" x 3/4" NPT F
1	4098.7-10	Pressure Shell	1	FRP	Opt for blue or white
Ref.	Part Number	Description	Qty.	Material	Note

Shell Length Code	Shell Number	L (MM)	S (MM)	Approx assembly weight (KG/LB)
1	4098.7	1163/45.8	600/23.6	6.6/14.8
2	4098.8	2179/85.8	1200/47.2	10/22.5
3	4098.9	3195/125.8	2200/86.6	13.5/30.3
4	4098.10	4211/165.8	1608/63.3x2	17/37.4

ROPV	DESIGN	Harbin ROPV Industry Development Center	
	REVIEW	MODEL	R4040A300E PRESSURE VESSEL
	APPROVAL	DRG	R4040A300E-00
		REV	08